



S2F SERIES BALL VALVE

MSS SP-110 Compliant



Complies with NACE MR0175,
ISO 15156 & NACE MR 0103

Features:

- 316 Stainless Steel Full Port Ball Valve
- ISO 5211 Mounting Pad
- 1000 psi WOG - 150 WSP
- Blow Out Proof Stem
- PTFE with Viton® O-Ring Backed Seats for Low Torque
- Temperature 0°F to 366°F

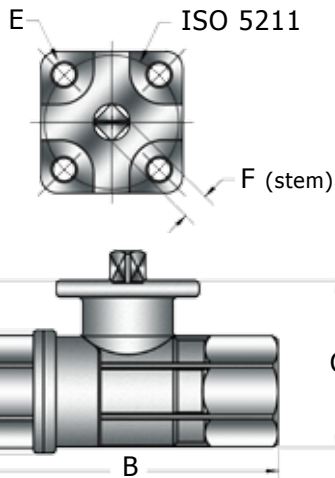

Dimensions

| PART # | NPT | A | B | C | D | E | F in/mm | ISO 5211 | Break Torque in/Lbs | Cv | Wt |
|--------|--------|------|------|------|------|--------------|------------|-------------|---------------------------|-----|-------|
| S2F-2 | 1/4" | 1.52 | 2.56 | 2.24 | 1.44 | 0.24 | .35/9 | F03 F04 | 27 | 7 | 0.95 |
| S2F-3 | 3/8" | 1.52 | 2.56 | 2.24 | 1.44 | 0.24 | .35/9 | F03 F04 | 27 | 10 | 0.89 |
| S2F-4 | 1/2" | 1.28 | 2.63 | 1.96 | 1.35 | 0.24 | .35/9 | F03 | 54 | 18 | 0.68 |
| S2F-6 | 3/4" | 1.36 | 3.07 | 2.19 | 1.65 | 0.24 | .35/9 | F03 | 54 | 34 | 0.91 |
| S2F-8 | 1" | 1.75 | 3.54 | 2.76 | 2.02 | 0.24 | .35/9 | F03 | 54 | 49 | 1.35 |
| S2F-10 | 1-1/4" | 1.89 | 3.93 | 3.16 | 2.53 | 0.24 | .35/9 | F03 | 54 | 103 | 2.22 |
| S2F-12 | 1-1/2" | 2.48 | 4.40 | 4.00 | 3.03 | 0.27 | .43/11 | F05 | 151 | 267 | 3.69 |
| S2F-16 | 2" | 2.84 | 5.31 | 4.75 | 3.81 | 0.27 | .43/11 | F05 | 151 | 307 | 6.49 |
| S2F-20 | 2 1/2" | 4.28 | 6.32 | 6.60 | 4.64 | 0.39 0.47 | .67/17 | F07 F10 | 484 | 322 | 16.38 |
| S2F-24 | 3" | 4.63 | 7.01 | 7.37 | 5.48 | 0.39 0.47 | .67/17 | F07 F10 | 772 | 584 | 22.82 |

Bill of Materials

| PART | Material |
|----------------|---------------|
| Body | CF8M |
| End Connection | CF8M |
| Ball | AISI 316-CF8M |
| Ball Seat | PTFE |
| Seat | PTFE |
| Stem Seal | PTFE |
| O-Rings | FKM (Viton®) |
| Stem | AISI 316 |
| Stem Seal | PTFE |

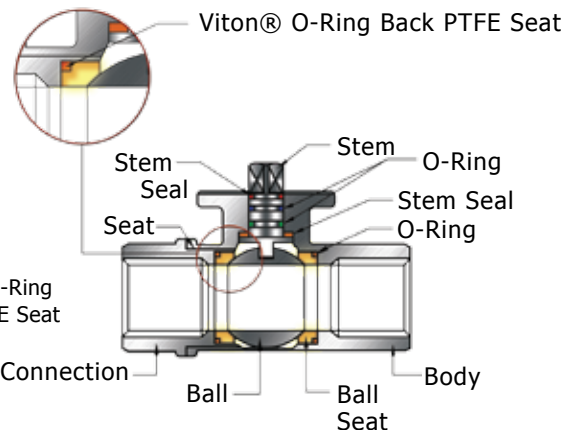

NOTE: O-Ring
Back PTFE Seat