



## S2F3M/C2F3M SERIES BALL VALVE



### Features:

- Direct Mount 2-Piece Ball Valve
- Available in Stainless Steel and Carbon Steel
- ISO 5211 Mounting Pad
- 29"Hg-3000psi (100°F), Tested to 4500psi
- Full Port Ball Valve (2" Reduced Port)
- Delrin® Seats, Viton® O-rings
- Blow-Out Proof Stem, Anti-Static Design
- NACE MR0175
- Temperature -20°F to 185°F

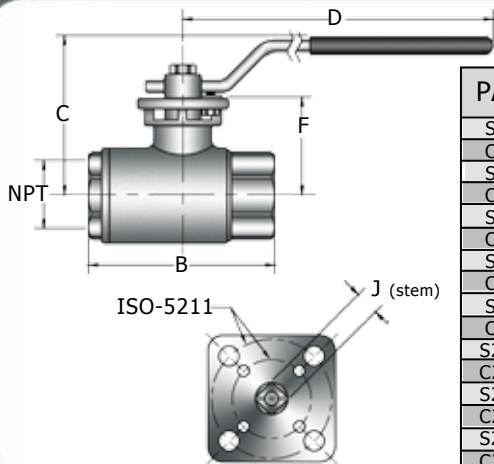

### Dimensions

PART #	NPT	ØA*	B	C	D	F	J in/mm	ISO 5211	Break Torque in/Lbs	Cv	Wt. Lbs.
S2F3M-2	1/4"	0.38	2.95	2.31	6.30	1.61	.35/9	F03/F04	101	5	2
C2F3M-2	1/4"	0.38	2.95	2.31	6.30	1.61	.35/9	F03/F04	101	5	2
S2F3M-3	3/8"	0.38	2.95	2.31	6.30	1.61	.35/9	F03/F04	104	8	2
C2F3M-3	3/8"	0.38	2.95	2.31	6.30	1.61	.35/9	F03/F04	104	8	2
S2F3M-4	1/2"	0.50	2.95	2.31	6.30	1.61	.35/9	F03/F04	130	19	2
C2F3M-4	1/2"	0.50	2.95	2.31	6.30	1.61	.35/9	F03/F04	130	19	2
S2F3M-6	3/4"	0.69	3.19	2.60	6.30	1.72	.35/9	F03/F04	156	35	2
C2F3M-6	3/4"	0.69	3.19	2.60	6.30	1.72	.35/9	F03/F04	156	35	2
S2F3M-8	1"	0.87	3.58	3.02	6.30	2.11	.43/11	F04/F05	208	50	4
C2F3M-8	1"	0.87	3.58	3.02	6.30	2.11	.43/11	F04/F05	208	50	4
S2F3M-10	1-1/4"	1.14	4.33	3.19	6.30	2.32	.43/11	F04/F05	390	110	5
C2F3M-10	1-1/4"	1.14	4.33	3.19	6.30	2.32	.43/11	F04/F05	390	110	5
S2F3M-12	1-1/2"	1.37	4.76	3.84	8.27	2.96	.55/14	F04/F05	468	180	9
C2F3M-12	1-1/2"	1.37	4.76	3.84	8.27	2.96	.55/14	F04/F05	468	180	9
S2F3M-16	2"	1.37	5.71	4.14	8.27	2.96	.55/14	F04/F05	468	210	11
C2F3M-16	2"	1.37	5.71	4.14	8.27	2.96	.55/14	F04/F05	468	210	11

### Bill of Materials

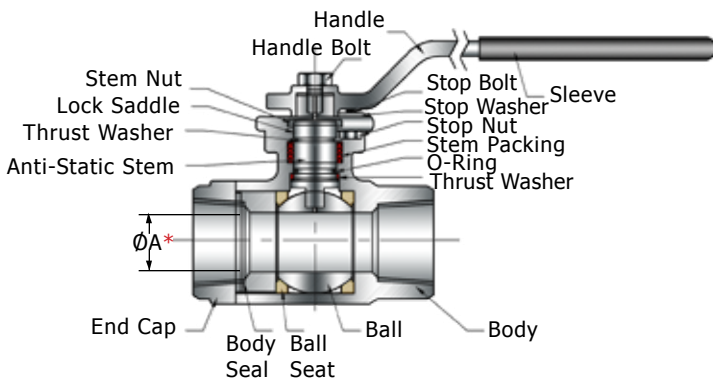

PART	Material
Body	Stainless / Carbon
End Cap	CF8M / WCB
Ball	CF8M
Anti-static Stem	316 Stainless Steel
Ball Seat	Delrin
Body Seal	PTFE
Thrust Washer	PTFE
Stem Packing	PTFE
O-ring	Viton®
Thrust Washer (2)	50% SS - 50% PTFE
Stem Nut	304 Stainless Steel
Lock Saddle	304 Stainless Steel
Handle	304 Stainless Steel
Stop Bolt	304 Stainless Steel
Stop Nut	304 Stainless Steel
Stop Washer	304 Stainless Steel
Handle Bolt	304 Stainless Steel
Handle Sleeve	Vinyl