

Universal
Components
Inc.

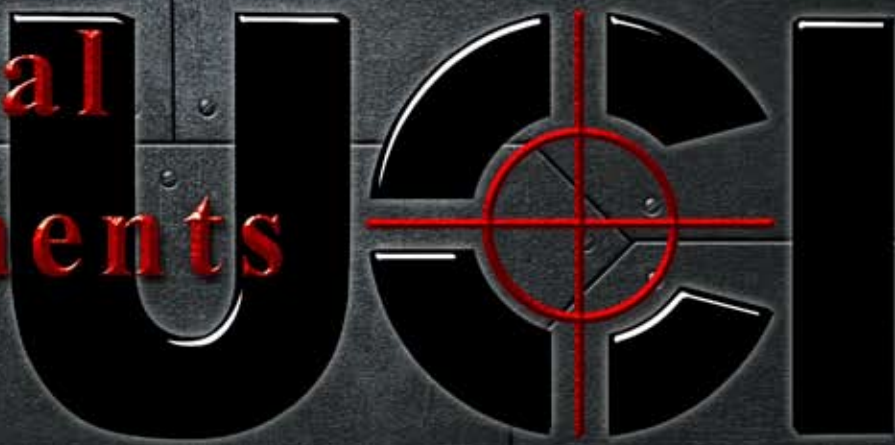

Filters &
Mufflers



SBM and SSBM Mufflers

Features:

SBM Series:

- Electroless Nickel Plated Steel Fitting
- 40 Micron Sintered Bronze Element
- 300 PSIG Maximum Working Pressure
- Temperature 35°F to 300°F

SSBM Series:

- 303 Stainless Steel Body
- 70 Micron Sintered 316 S.S. Element
- 300 PSIG Maximum Working Pressure
- Temperature 35°F to 392°F



SBM



SSBM

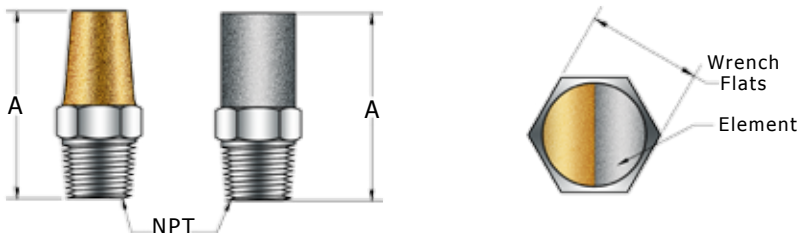

Dimensions:

Part	NPT Size	A	Wrench Flats	Body	Element
SBM-M	10/32"	0.70	5/16"	Electroless Nickel Plated Steel Fitting	40 Micron Sintered Bronze
SBM-1	1/8"	0.90	7/16"		
SBM-2	1/4"	1.38	9/16"		
SBM-3	3/8"	1.50	11/16"		
SBM-4	1/2"	1.88	7/8"		
SBM-6	3/4"	2.25	1-1/16"		
SBM-8	1"	2.88	1-5/16"		
SBM-10	1-1/4"	3.25	1-11/16"		
SBM-12	1-1/2"	3.69	2"	303 Grade Stainless Steel	316 Stainless Steel, 70 Micron
SSBM-M	10/32"	0.72	5/16"		
SSBM-1	1/8"	1.09	1/2"		
SSBM-2	1/4"	1.38	5/8"		
SSBM-3	3/8"	1.88	3/4"		
SSBM-4	1/2"	2.25	1-5/16"		
SSBM-6	3/4"	2.80	1-1/8"		
SSBM-8	1"	3.17	1-1/2"		

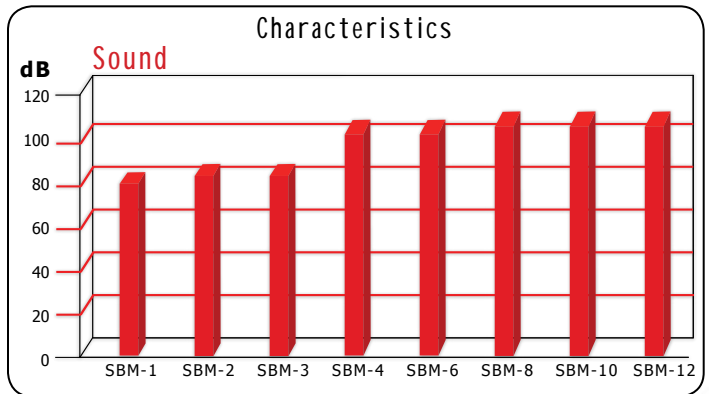
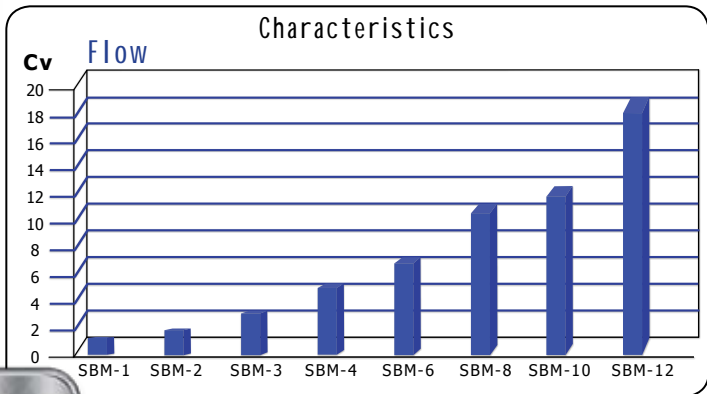



BV and SSBV Breather Vent

Features:

BV Series:

- Electroless Nickel Plated Steel Fitting
- 40 Micron Sintered Bronze Element
- 150 PSIG Maximum Working Pressure
- Temperature 35°F to 300°F

SSBV Series:

- 303 Stainless Steel Body
- 70 Micron Sintered 316 S.S. Element
- 150 PSIG Maximum Working Pressure
- Temperature 35°F to 392°F



BV



SSBV

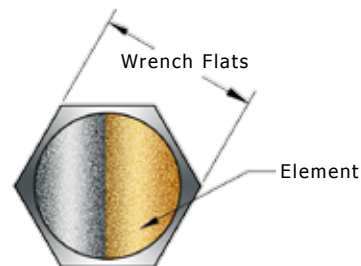

Dimensions:

Part	NPT Size	A	Wrench Flats	Body	Element
BV-1	1/8"	0.44	7/16"	Electroless Nickel Plated Steel Fitting	40 Micron Sintered Bronze
BV-2	1/4"	0.63	9/16"		
BV-3	3/8"	0.75	11/16"		
BV-4	1/2"	0.88	7/8"		
BV-6	3/4"	1.00	1-1/16"		
BV-8	1"	1.31	1-5/16"		
BV-10	1-1/4"	1.41	1-11/16"		
BV-12	1-1/2"	1.50	2"		
SSBV-1	1/8"	0.58	1/2"	303 Grade Stainless Steel	316 Stainless Steel, 70 Micron
SSBV-2	1/4"	0.78	5/8"		
SSBV-3	3/8"	0.81	3/4"		
SSBV-4	1/2"	0.96	1-5/16"		
SSBV-6	3/4"	1.05	1-1/8"		
SSBV-8	1"	1.30	1-1/2"		

Characteristics

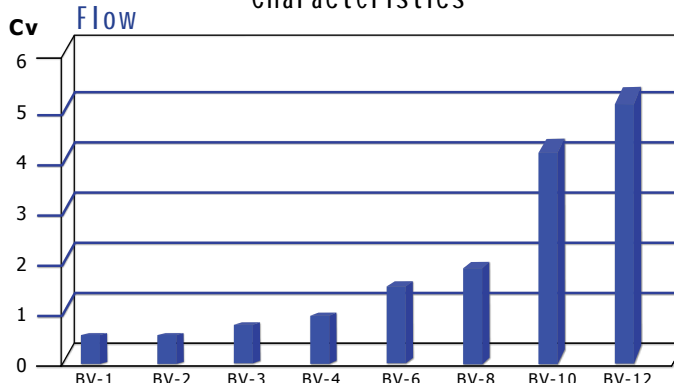



SCM and SSCM Series Speed Control Muffler

Features:

SCM Series:

- Brass Construction
- 40 Micron Sintered Bronze Element
- 300 PSIG Maximum Working Pressure
- Temperature 35°F to 300°F

SSCM Series:

- 303 Stainless Steel Body
- 70 Micron Sintered 316 S.S. Element
- 300 PSIG Maximum Working Pressure
- Temperature 35°F to 392°F



SCM

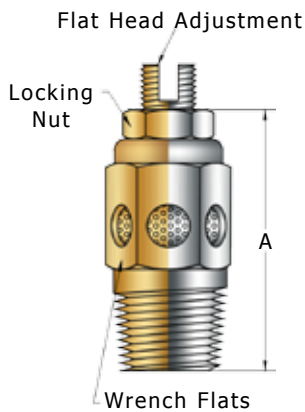

SCM-1	0 to 30	SCFM
SCM-2	0 to 40	SCFM
SCM-3	0 to 62	SCFM
SCM-4	0 to 103	SCFM
SCM-6	0 to 110	SCFM
SCM-8	0 to 140	SCFM



SSCM

Dimensions:

Part	NPT Size	A	Height Full Open	Wrench Flats	Body	Element
-	SCM-1	1/8"	1.31	1.5	1/2"	Brass Fitting 40 Micron Sintered Bronze
SCM-1-H*	SCM-2	1/4"/1/8"*	1.56	1.8	6/16"	
SCM-2-H*	SCM-3	3/8"/1/4"*	1.63	2	11/16"	
SCM-3-H*	SCM-4	1/2"/3/8"*	2.00	2.4	7/8"	
SCM-4-H*	SCM-6	3/4"/1/2"*	2.38	2.9	1-1/16"	
-	SCM-8	1"	2.50	3.1	1-5/16"	303 Grade Stainless Steel 316 Stainless Steel, 70 Micron
-	SSCM-1	1/8"	1.53	1.5	1/2"	
-	SSCM-2	1/4"	1.92	1.8	9/16"	
-	SSCM-3	3/8"	2.06	2	11/16"	
-	SSCM-4	1/2"	2.39	2.4	7/8"	
-	SSCM-6	3/4"	2.84	2.9	1-1/16"	
-	SSCM-8	1"	3.06	3.1	1-3/8"	

* High Flow

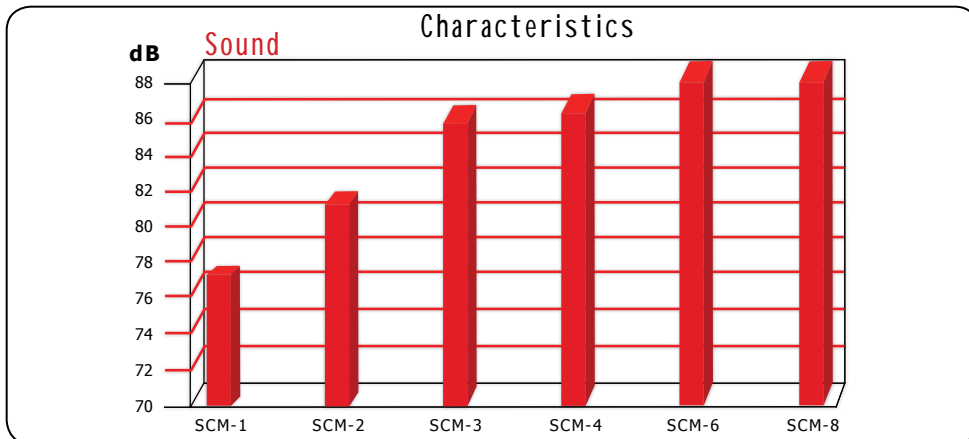



HPM Series Mufflers

Features:

HPM Series:

- Nylon Housing
- Stainless Steel Wire Element
- 150 PSIG Maximum Working Pressure
- Temperature 35°F to 120°F

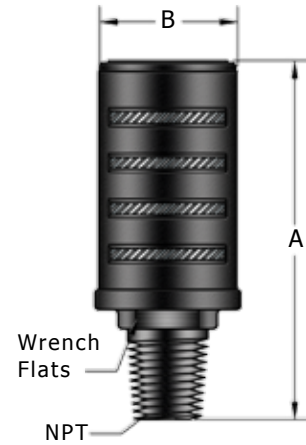

Dimensions:

Part	NPT Size	A	B	Wrench Flats	Body	Screen
HPM-1	1/8"	2.13	0.83	13/16"	Nylon	Stainless Steel Wire
HPM-2	1/4"	2.25	0.83	13/16"		
HPM-3	3/8"	3.44	1.25	1 1/4"		
HPM-4	1/2"	3.56	1.25	1 1/4"		

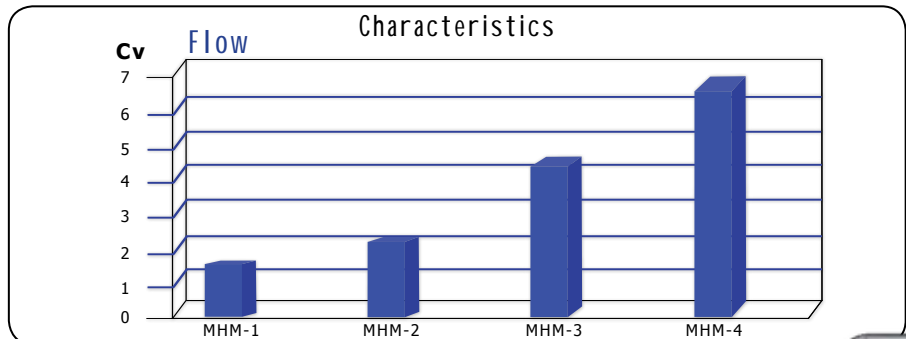
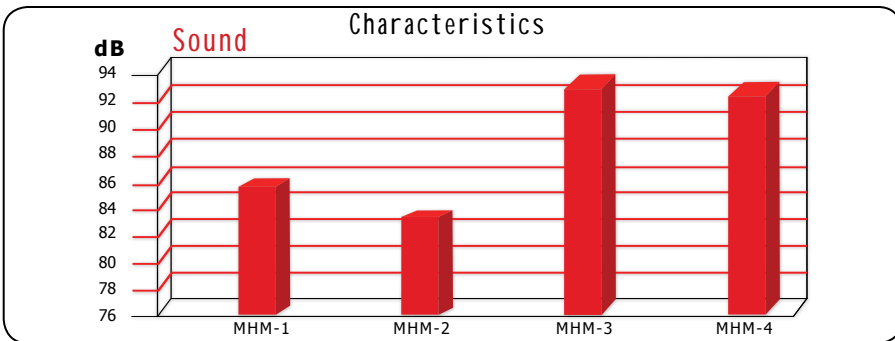



MHS and MHA Series Mufflers

Features:

MHS Series:

- Steel Housing
- Stainless Steel Wire Element
- 300 PSIG Maximum Working Pressure
- Temperature 35°F to 160°F

MHA Series:

- Aluminum Housing
- 50 Mesh Stainless Steel Wire Element
- 300 PSIG Maximum Working Pressure
- Temperature 35°F to 160°F

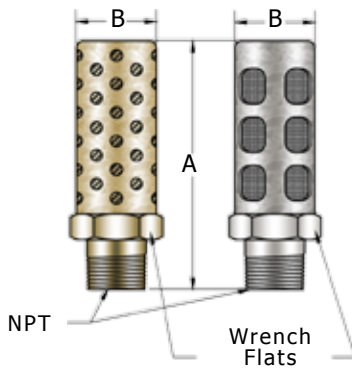

MHS



MHA

Dimensions:

Part	NPT Size	A	B	Wrench Flats	Body	Screen
MHS-1	1/8"	1.38	0.43	7/16"	Steel	50 Mesh Stainless Steel Screen
MHS-2	1/4"	1.75	0.56	9/16"		
MHS-3	3/8"	2.25	0.70	11/16"		
MHS-4	1/2"	2.75	0.87	7/8"		
MHS-6	3/4"	3.06	1.06	1-1/16"		
MHS-8	1"	3.88	1.31	1-5/16"		
MHS-10	1-1/4"	4.50	1.68	1-11/16"		
MHS-12	1-1/2"	5.00	1.97	2"		
MHS-16	2"	5.50	2.30	2-3/8"	Aluminum	50 Mesh Stainless Steel Screen
MHA-1	1/8"	1.44	0.44	7/16"		
MHA-2	1/4"	1.80	0.57	9/16"		
MHA-3	3/8"	2.30	0.69	11/16"		
MHA-4	1/2"	2.78	0.88	7/8"		
MHA-6	3/4"	3.19	1.05	1-1/16"		
MHA-8	1"	3.89	1.31	1-5/16"		

Characteristics

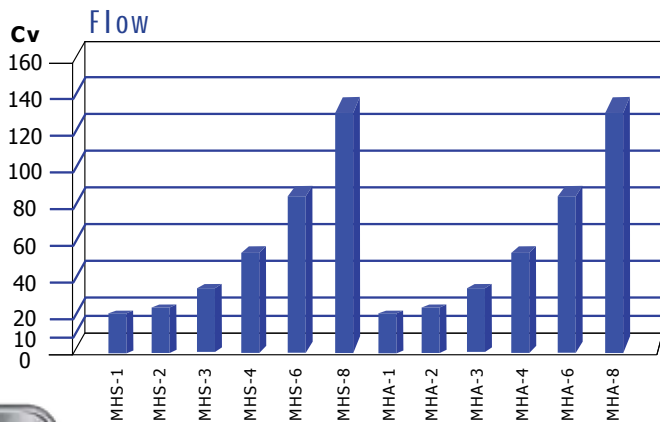

Characteristics

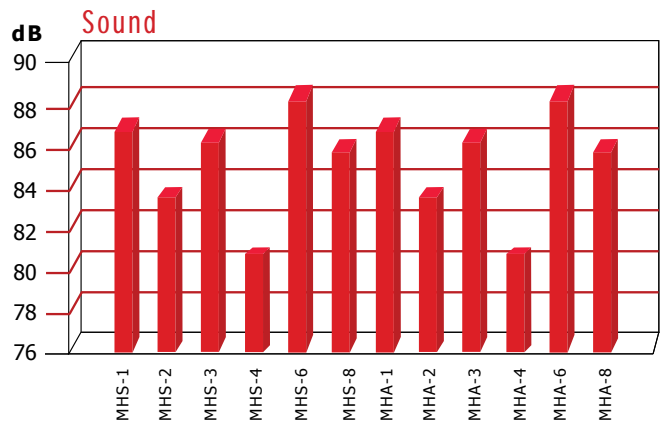



MHM and FHM Series Mufflers

Features:

MHM and FHM Series:

- Aluminum Housing
- Stainless Steel Wire Screen
- 300 PSIG Maximum Working Pressure
- Temperature 35°F to 160°F

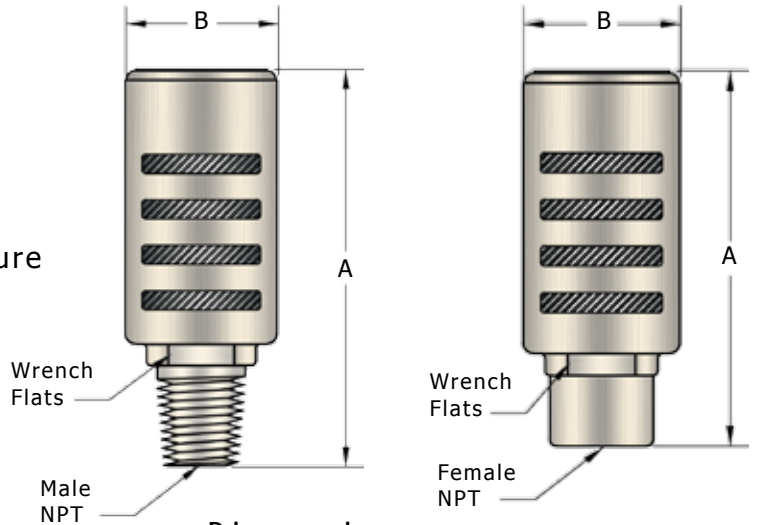

MHM



FHM

Dimensions:

Part	NPT Size	A	B	Wrench Flats	Body	Screen
MHM-1	1/8"	1.88	0.80	5/8"	Aluminum Note: Available in Stainless Steel	Stainless Steel Wire
MHM-2	1/4"	1.88	0.80	5/8"		
MHM-3	3/8"	3.25	1.23	1"		
MHM-4	1/2"	3.25	1.23	1"		
MHM-6	3/4"	4.63	2.00	1-5/8"		
MHM-8	1"	4.63	2.00	1-5/8"		

Part	NPT Size	A	B	Wrench Flats	Body	Screen
FHM-1	1/8"	1.88	0.80	5/8"	Aluminum Note: Available in Stainless Steel	Stainless Steel Wire
FHM-2	1/4"	1.88	0.80	5/8"		
FHM-3	3/8"	3.25	1.23	1"		
FHM-4	1/2"	3.25	1.23	1"		
FHM-6	3/4"	4.63	2.00	1-5/8"		
FHM-8	1"	4.63	2.00	1-5/8"		
FHM-10	1-1/4"	5.50	C/F	2-1/2"		
FHM-12	1-1/2"	5.50	C/F	2-1/2"		
FHM-16	2"	6.44	C/F	3"		

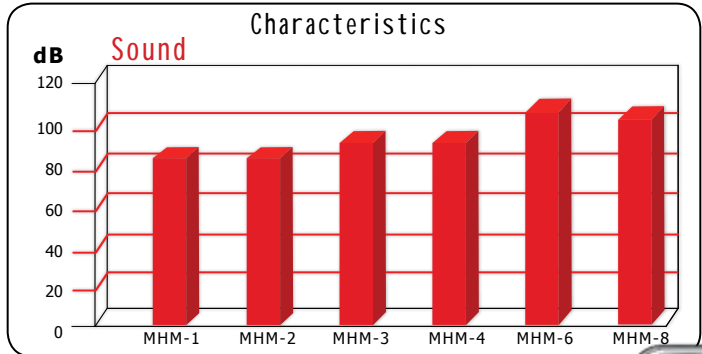
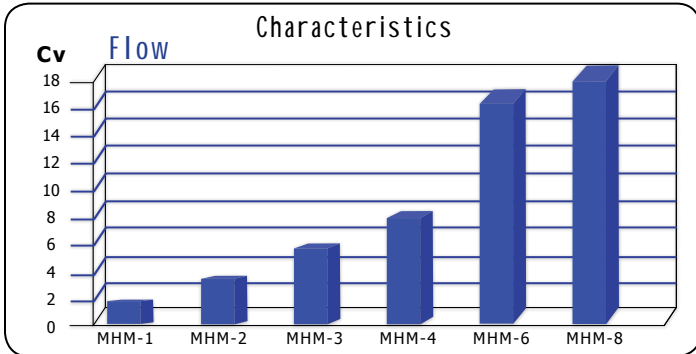



HIT Series Hydraulic IN-LINE T-Type Filters

Features:

HIT Series:

- Clear Anodized Aluminum
- 25 Micron Sintered Bronze Element
- 5000 PSIG (Hydraulic only) Max. Working Pressure
- Buna-N Seals 35°F to 200°F

Options:

Viton Seals, Suffix "V" 35°F to 400°F
 Micron Size, Suffix "10", "40", "90"
 (Example HIT-290), (Kit Example EK2-90)

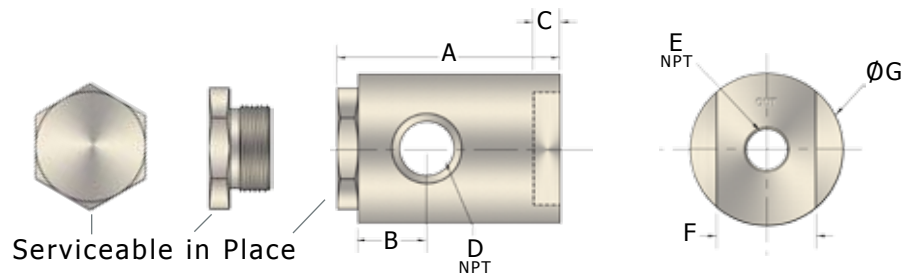

Dimensions:

Part	A	B	C	D NPT	E NPT	F	ØG	spring Kit	element Kit	Body	Element
HIT-2	3.18	0.96	0.38	1/4"	1/4"	1.38	2.13	SK2T	EK2	2011-T3 Aluminum	25 Micron Sintered Bronze
HIT-2V	3.18	0.96	0.38	1/4"	1/4"	1.38	2.13	SK2T	EK2V		
HIT-3	3.18	0.96	0.38	3/8"	3/8"	1.38	2.13	SK2T	EK2		
HIT-3V	3.18	0.96	0.38	3/8"	3/8"	1.38	2.13	SK2T	EK2V		

Part	A	B	C	D NPT	E NPT	F	ØG	spring Kit	element Kit	Body	Element
HIT-S6	3.18	1.01	0.38	3/8"	9/16"	1.38	2.13	SK2T	EK2	2011-T3 Aluminum	25 Micron Sintered Bronze
HIT-S6V	3.18	1.01	0.38	3/8"	9/16"	1.38	2.13	SK2T	EK2V		

Characteristics

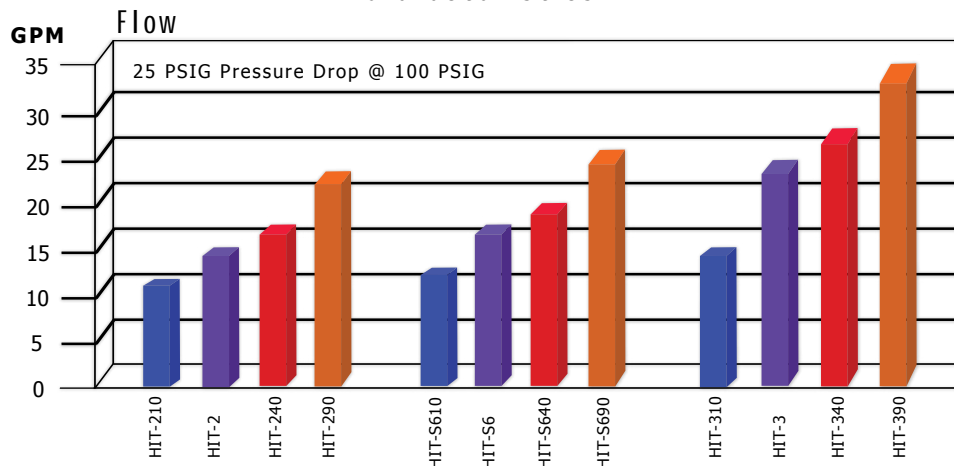



HIF Series Hydraulic IN-LINE Filters

Features:

HIF Series:

- Clear Anodized Aluminum Filter
- 25 Micron Sintered Bronze Element
- 3000 PSIG (Hydraulic only) Max. Working Pressure
- Buna-N Seals 35°F to 200°F

Options:

Viton Seals, Suffix "V" 35°F to 400°F
 Micron Size, Suffix "10", "40", "90"
 (Example HIF-290), (Kit Example EK2-90)

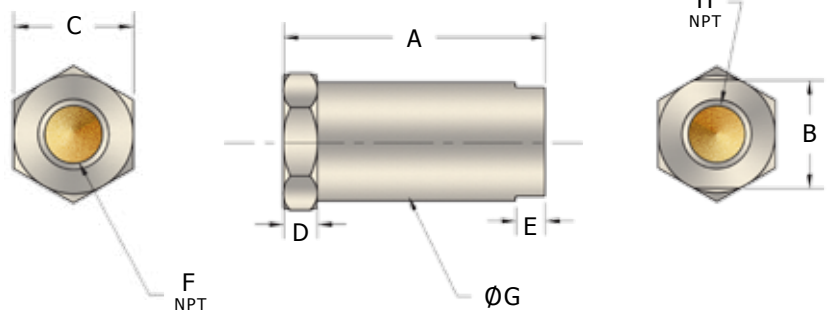

Dimensions:

Part	A	B	C	D	E	F NPT	ØG	H NPT	spring Kit	element Kit	Body	Element
HIF-2	3.30	1.38	1.50	0.43	0.37	1/4"	1.50	1/4"	SK2	EK2	2011-T3 Aluminum	25 Micron Sintered Bronze
HIF-2V	3.30	1.38	1.50	0.43	0.37	1/4"	1.50	1/4"	SK2	EK2V		
HIF-3	3.30	1.38	1.50	0.43	0.37	3/8"	1.50	3/8"	SK2	EK2		
HIF-3V	3.30	1.38	1.50	0.43	0.37	3/8"	1.50	3/8"	SK2	EK2V		
HIF-4	4.92	1.38	1.50	0.45	0.37	1/2"	1.50	1/2"	SK4	EK4		
HIF-4V	4.92	1.38	1.50	0.45	0.37	1/2"	1.50	1/2"	SK4	EK4V		
HIF-6	4.92	1.38	1.50	0.45	0.37	3/4"	1.50	3/4"	SK4	EK4		
HIF-6V	4.92	1.38	1.50	0.45	0.37	3/4"	1.50	3/4"	SK4	EK4V		

Part	A	B	C	D	E	F SAE	ØG	H SAE	spring Kit	element Kit	Body	Element
HIF-S6	3.30	1.38	1.50	0.43	0.37	9/16"	1.50	9/16"	SK2	EK2	2011-T3 Aluminum	25 Micron Sintered Bronze
HIF-S6V	3.30	1.38	1.50	0.43	0.37	9/16"	1.50	9/16"	SK2	EK2V		
HIF-S8	3.30	1.38	1.50	0.43	0.37	1/2"	1.50	1/2"	SK2	EK2		
HIF-S8V	3.30	1.38	1.50	0.43	0.37	1/2"	1.50	1/2"	SK2	EK2V		

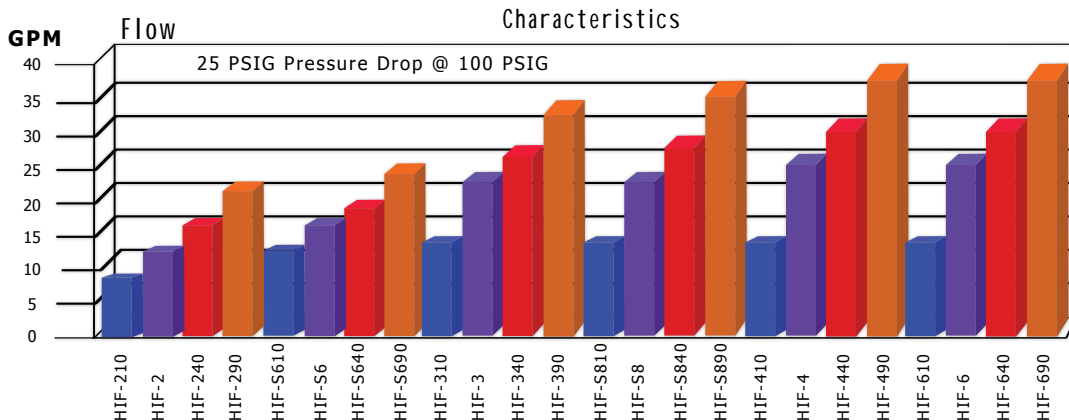



PIF Series Pneumatic Filters

Features:

PIF Series:

- (PIF) Aluminum Housing, (PIFB) Brass Housing
- 40 Micron Sintered Bronze Element
- 500 PSIG Maximum Working Pressure
- Buna-N Seals 35°F to 200°F
- M=Female Inlet/Male Outlet
- Female Inlet/Female Outlet: PIF-4 & PIF-6

Options:

- Viton Seals, Suffix "V" 35°F to 400°F
- Micron Size, Suffix "20", "90"
- (Example PIF-1M90), (Kit Example EK2-90)

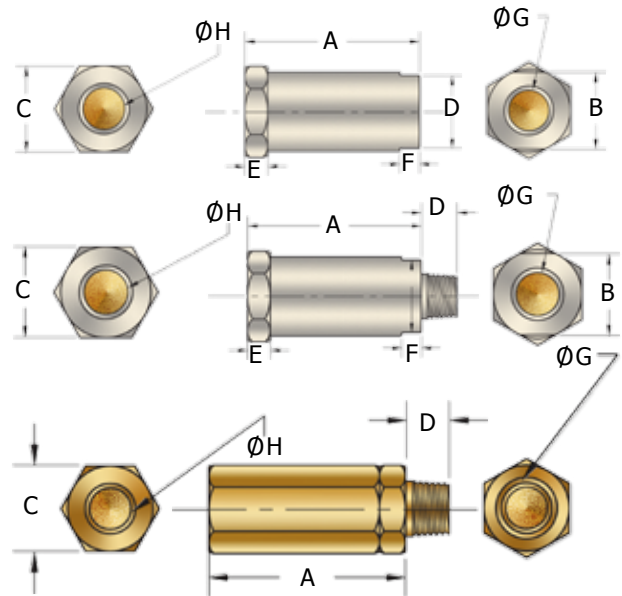
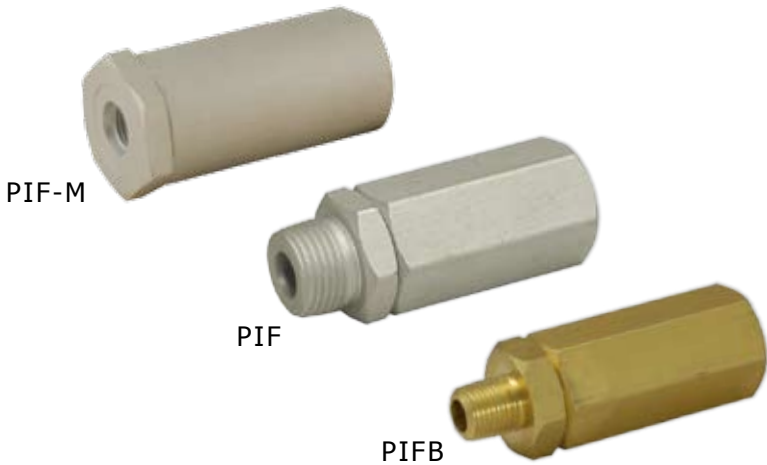

Dimensions:

Part	A	B	C	D	E	F	ØG NPT	ØH NPT	spring Kit	element Kit	Body	Element
PIFB-1M	1.88	-	0.74	0.41	-	-	1/8"	1/8"	SKP2	EKP2	Brass	40 Micron Sintered Bronze
PIF-1M	1.88	-	0.74	0.41	-	-	1/8"	1/8"	SKP2	EKP2	2011-T3 Aluminum	
PIF-2M	2.29	-	0.74	0.41	-	-	1/4"	1/4"	SKP2	EKP2		
PIF-3M	1.87	-	0.86	0.44	-	-	3/8"	3/8"	SKP2	EKP2		
PIF-4	3.30	1.38	1.50	1.38	0.43	0.37	1/2"	1/2"	SKP4	EKP4		
PIF-4M	3.30	1.38	1.50	0.68	0.43	0.37	1/2"	1/2"	SKP4	EKP4		
PIF-6	3.30	1.38	1.50	1.38	0.43	0.37	3/4"	3/4"	SKP4	EKP4		
PIF-6M	3.30	1.38	1.50	0.68	0.43	0.37	3/4"	3/4"	SKP4	EKP4		

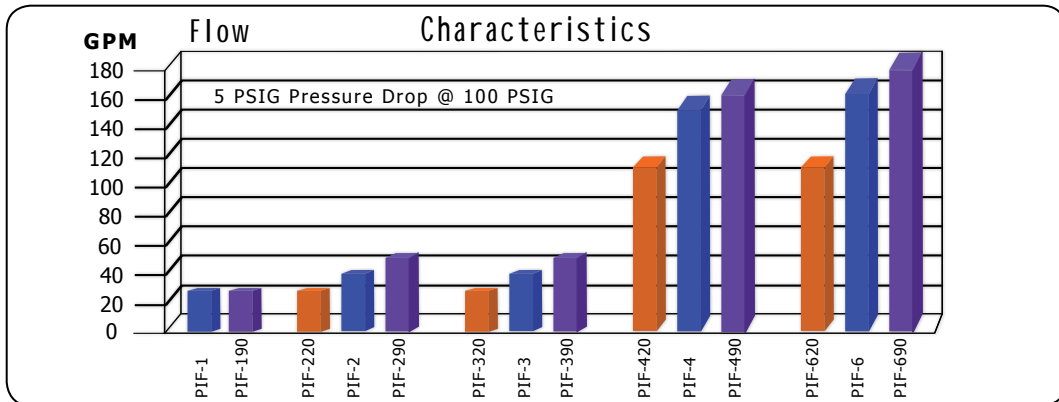

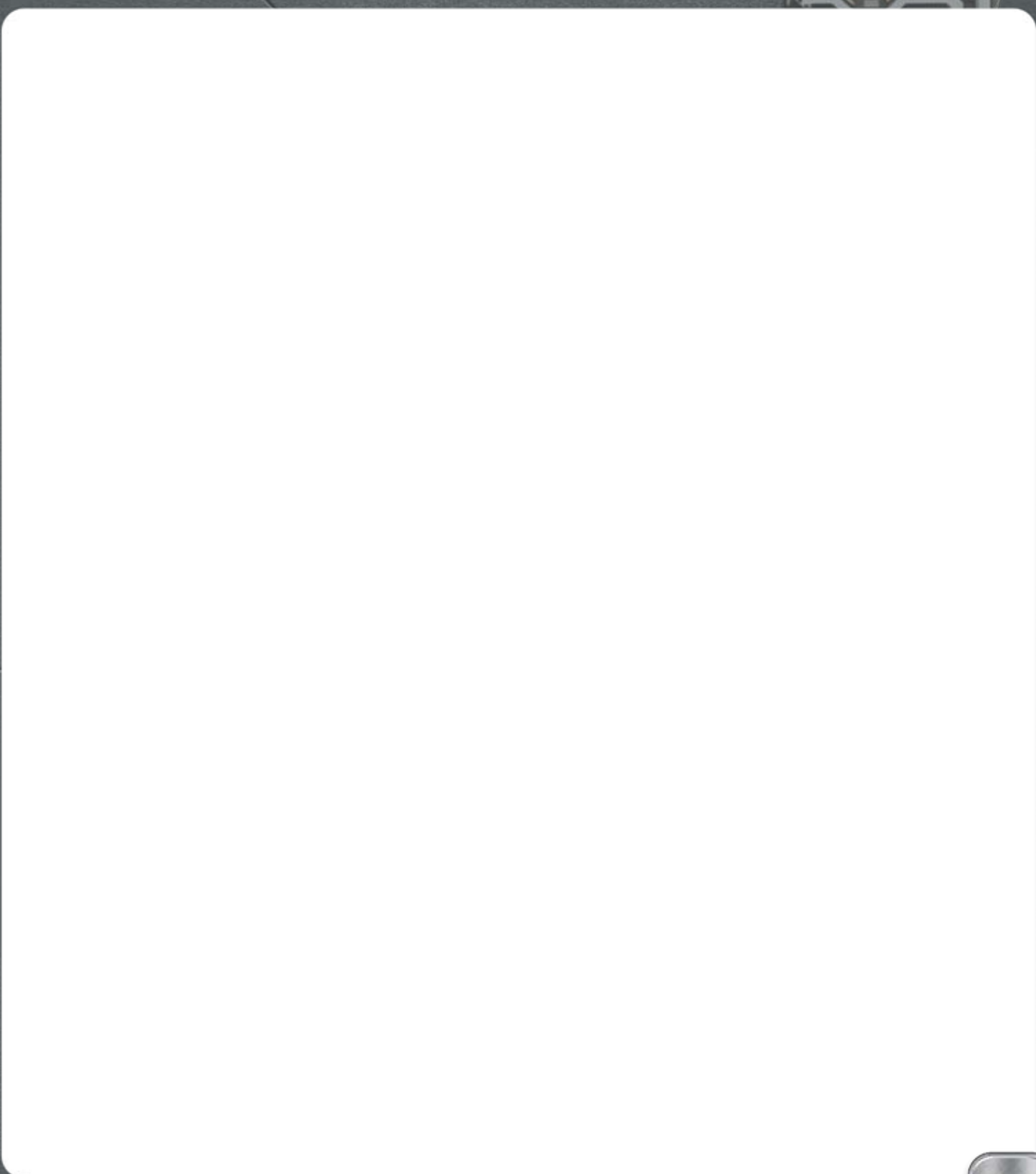

**Universal
Components
Inc.**



1313 Hall Spencer Road
Rock Hill, S.C. 29730

Phone: 803-324-5176

Fax: 803-324-2640

www.ucimfg.com

sales@ucimfg.com